

POWER TRANSFORMERS

Rectifier Transformers

Style NV with lugs

—Rectifiers not included

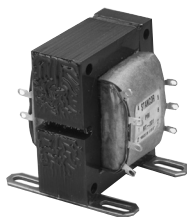

All Primaries 117 Volts 50/60 Hz - Solder Lug Termination

Sec.	STANCOR PART NUMBER	Style	Rectifier Circuit	Range of Applied A.C. Volts Under Load (Approx.)	Output Resistive or Inductive Load		Output Capacitive Load*		DIMENSIONS-INCHES					Weight (lbs.)	Agency Certif.
					Max. D.C. (Volts)	(Amps)	Max D.C. (Volts)	(Amps)	H	Case W	D	Mounting MW	MD		
A	RT-201	NV	C.T. Bridge	11.7 to 29.4	11.2	2.00	13.8 ¹	2.00	3.13	2.50	2.38	2.00	2.06	2.5	-
				11.1 to 28.5	23.0	1.25	30.0 ²	1.25							
	RT-202	NV	C.T. Bridge	12.0 to 29.8	11.1	4.00	14.7 ³	4.00	3.50	2.81	2.75	2.25	2.28	3.8	-
				12.0 to 29.8	24.3	2.00	33.0 ¹	2.00							
B	RT-204	NV	C.T. Bridge	11.7 to 29.2	12.0	8.00	14.5 ⁴	8.00	3.88	3.13	3.88	2.50	2.72	6.1	-
				11.6 to 29.2	24.0	4.00	32.4 ³	4.00							
	RT-206	NV	C.T. Bridge	12.0 to 29.7	11.5	12.0	14.4 ⁵	12.0	4.31	3.44	4.25	2.75	3.13	8.7	-
				12.0 to 29.7	24.0	6.00	32.0 ⁶	6.00							
C	RT-208	NV	C.T. Bridge	12.1 to 29.2	11.4	15.0	14.8 ⁷	15.0	4.63	3.75	5.25	3.00	3.62	12.4	-
				12.1 to 29.2	23.7	8.00	32.5 ⁴	8.00							
D	RT-402	NV	C.T. Bridge	23.0 to 58.0	25.0	4.00	33.5 ⁶	4.00	3.81	3.13	4.50	2.50	2.72	6.9	-
				23.0 to 58.0	51.5	2.00	72.5 ⁹	2.00							
	RT-408	NV	C.T. Bridge	25.0 to 54.1	23.4	12.0	32.0 ¹	12.0	5.41	4.38	6.75	3.50	5.25	26.5	-
				25.0 to 54.1	46.3	8.00	66.8 ⁴	8.00							

* Indicates Filter Capacitor Size: 1 = 1000 MFD, 2 = 500 MFD, 3 = 2000 MFD, 4 = 4000 MFD, 5 = 6000 MFD, 6 = 3000 MFD, 7 = 7500 MFD, 8 = 12000 MFD, 9 = 15000 MFD

Rectifier Transformers

Each transformer has the winding arrangement and terminal numbering shown in the schematic diagrams. The primary windings may be used in series to raise or lower the secondary voltage output. A variety of combinations is possible using the taps on both windings for "Aiding" or "Bucking" action.

Designed for 117 V, 50/60 cycle operation; however, may be satisfactorily operated at 400 cycles.

The secondary winding of each transformer consists of two identical windings connected to terminals 8 & 9 and to 10 & 11 respectively. Use the tables showing the various output voltages for specific terminal connections as your guide. Many combinations are possible other than those listed in the tables. All ratings shown are for normal convection air cooled applications. Select only rectifiers capable of handling the voltages and currents described.

When operating these transformers continuously at maximum rated output voltage and current and because of certain other conditions, it is sometimes necessary to derate the rectified output current (D.C.) as much as 20%, in order to stay within the recommended operating temperature limit of 105 degrees Centigrade. The type of rectifier circuit and load (capacitive, inductive, or resistive) determines the relative amount of current (RMS) in the transformer

secondary winding. The relationship of A.C. to D.C. (secondary RMS current to rectified D.C. output) for typical circuits and loads is given in the technical data on page 7 of this section. Operating duty cycle, type of cooling (natural convection in free air or otherwise) and the power line input voltage and frequency also have an effect on the transformer temperature. These things should all be properly related to the results in any specific application.

The "RT-Series" of transformers may also be used in rectifier circuits other than the Full-wave C.T. and Full-wave Bridge. In circuits such as the Half-wave or Full-wave Voltage Doubler (symmetrical) and Full-wave Bridge, where a C.T. connection is not required, both secondary windings may be connected in parallel, to double the RMS current that is available from each secondary separately. The RMS voltage will, of course, be half of the amount available as that obtained with the secondaries connected in the series. Please refer to page 7 of this section to obtain the secondary RMS current as related to each rectifier circuit and type of load.

Voltages expressed in the tables are approximate and will vary within plus or minus two (2) Volts.

Rectifier Transformers - Terminal Connection Data

How to Determine Secondary AC (RMS) Current Ratings

The tabular data for the various Rectifier, Control and Filament types of transformers listed in this catalog shows A.C. (RMS) secondary current, unless otherwise indicated as in the "RT" series listings.

When used in various rectifier circuits, with the possibility of different types of loads, the RMS secondary current will be different for each specific condition. To assist the user, the following information is given so that the proper transformer may be selected.

The rectifier circuits as related to these transformers are:

- HW = Half-Wave
- FWCT = Full-Wave Center Tap
- FWB = Full-Wave Bridge
- FWD = Full-Wave Doubler

The formula for the relation between secondary RMS current (**I_{ac}**) which the transformer has to deliver and the D.C. output current taken from the rectifier (**I_{dc}**) is: **I_{ac} = K_{FF} x I_{dc}** where **K_{FF}** is the form factor.

The factor for each circuit and type of load is as follows:

REACTOR LOAD		CAPACITOR LOAD	
Form Factor	Rectifier Circuit	Form Factor	Rectifier Circuit
1.25	HW	2.3	HW
0.7	FWCT	1.2	FWCT
1.0	FWB	1.8	FWB
		4.0 (approx.)	FWD

Only transformers with a CT connection are usable in the FWCT circuit and the FWD circuit will have only a capacitor load. The size and type of capacitors used in the FWD circuit will affect the form factor. The factor shown is an approximate maximum for the full-wave symmetrical voltage doubler circuit using two similar electrolytic capacitors.

The transformer selected for a specific D.C. output voltage and current rating, with known type of load after the rectifier, should deliver sufficient RMS voltage to make up for the voltage drop in each rectifier junction plus any drop in a filter or regulator that is used.

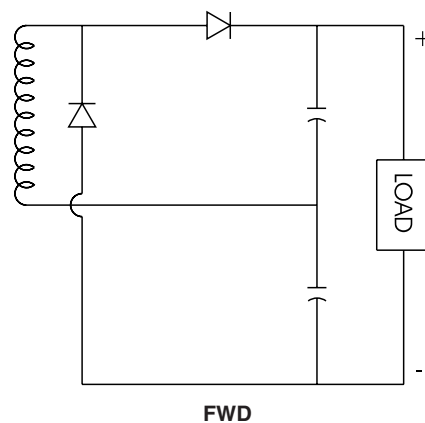
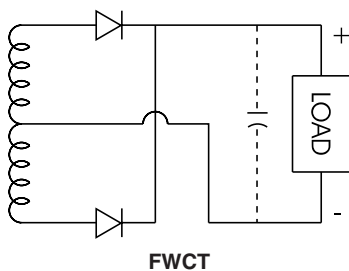
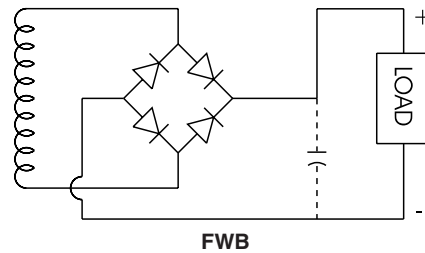
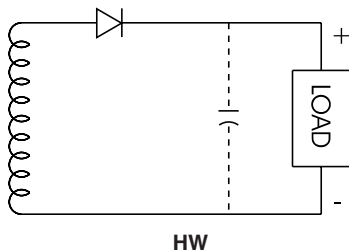

TECH TIP

Bucking/Aiding Coils

A "Buck-Boost" or "Bucking-Aiding" winding is a separate winding that when connected in the same rotation as the main winding adds the turns of the Buck-Boost winding to the turns of the main winding. If the Buck-Boost is connected in opposition to the main winding, it is equivalent to removing turns from the main winding.